



by  ALBINI & FONTANOT®

KOMPACT

English ASSEMBLY INSTRUCTIONS

Text Instructions Begin on Page 9

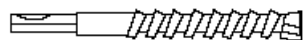

Ø 8x300 12x120 14x150 18x120 mm



Ø 4.5 8.5 mm

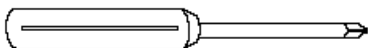

PH 2

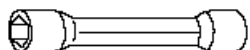

10-13-17 mm

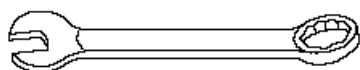

13-17-22 mm



2.5-3-5-6 mm

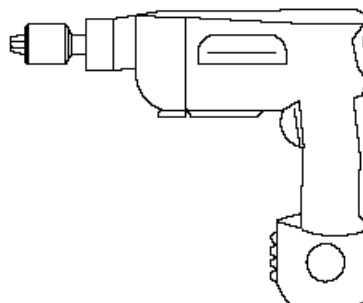
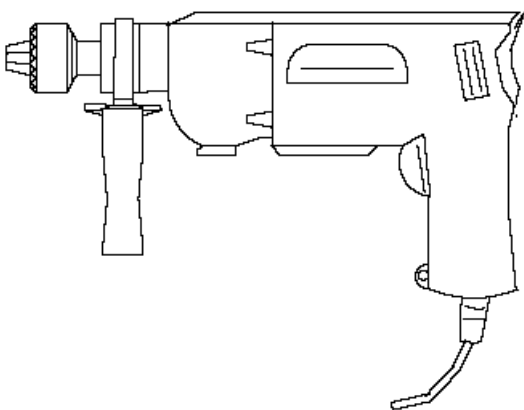
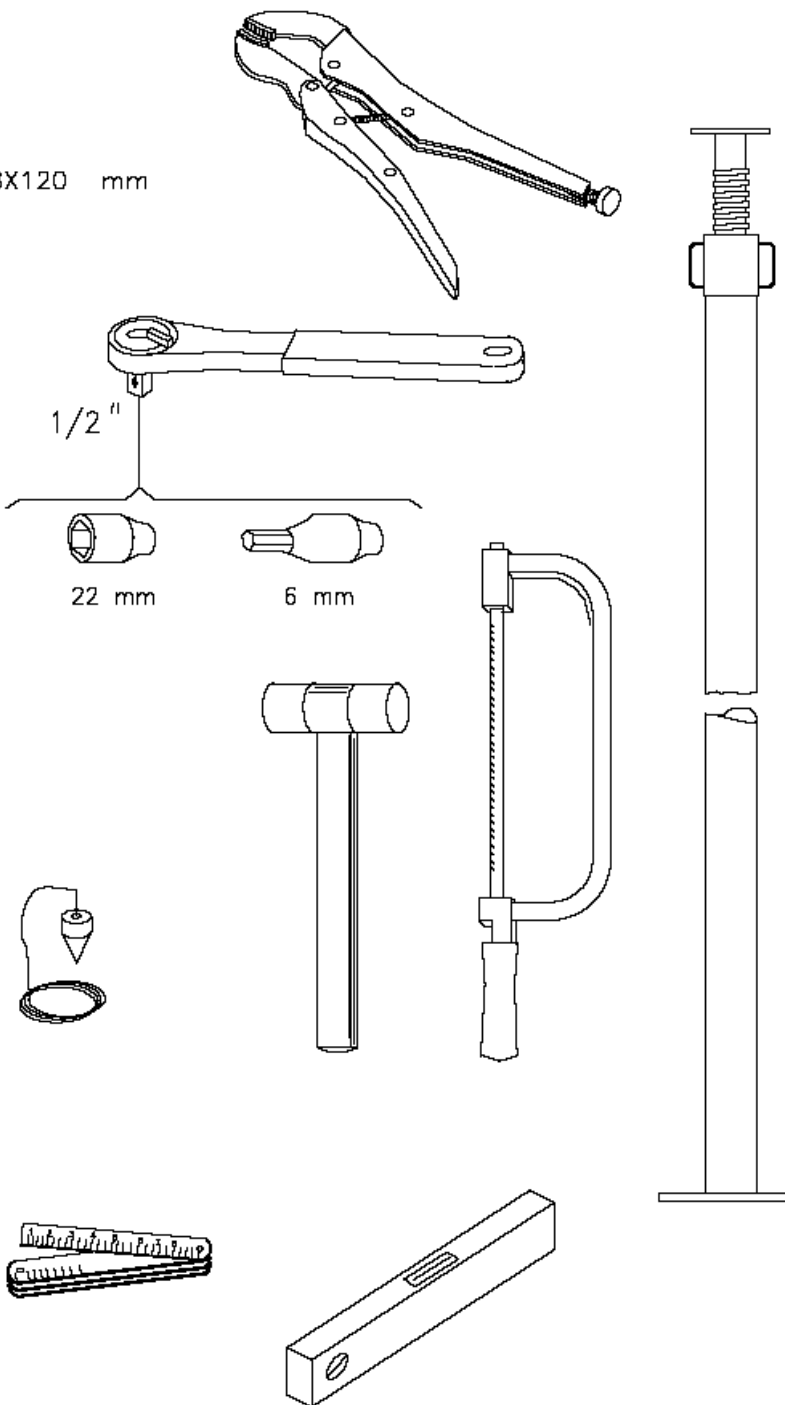

In order to proceed with the assembly, unpack all stair components and lay them out on a sufficiently large surface. Check all components for quantity, comparing with the list in TAB.1 (A = Code, B = Quantity). In the packing box you will find a videocassette showing the assembly. We suggest watching it before proceeding with the assembly.

Assembly

1. Measure carefully the floor-to-floor height (H) (FIG.2).
2. Calculate the height of the Rise:
deduct $8\frac{1}{8}$ " (height of the first rise) from the floor-to-floor height (H);
divide the result by the number of rises - 1 (divide by the number of treads, as the last rise is given by the distance between the last tread and the landing floor).
Example (FIG.2): with a floor-to-floor height of $8' 7\frac{1}{8}$ " and a staircase with 13 rises (i.e. with 12 treads): $(8' 7\frac{1}{8} " - 8\frac{1}{8} " / 13 - 1) = 8"$.
3. Measure carefully the ceiling opening (C) (FIG.2).
4. Calculate the measure of the Going (P).
With the version of the staircase L=74 (railing included) as in FIG.2A the calculation is the following:
a) Deduct from the measure (C) of the ceiling opening the following steady measures: 1) $11\frac{3}{8}$ " = depth of the last tread; 2) $2' 3\frac{1}{8}$ " = angle treads; 3) $\frac{3}{8}$ " = distance from the wall. b) Divide the result by the number of the remaining treads. Example: with a ceiling opening measure of $7' 7"$ and a staircase as in FIG.2A, the calculation is the following: $7' 7" - 11\frac{3}{8} " - 2' 3\frac{1}{8} " - \frac{3}{8} " / 6 = 8\frac{5}{8} "$ (= measure of the going).
With the version of the staircase L=89 (railing included) as in FIG.2B the calculation is the following:
a) Deduct from the measure (C) of the ceiling opening the following steady measures: 1) 2 " = depth of the last tread; 2) $2' 9\frac{1}{8}$ " = angle treads; 3) $\frac{3}{8}$ " = distance from the wall. b) Divide the result by the number of the remaining treads. Example: with a ceiling opening measure of $8' 7\frac{1}{8}$ " and a staircase as in FIG.2B, the calculation is the following: $8' 7\frac{1}{8} " - 2" - 2' 9\frac{1}{8} " - \frac{3}{8} " / 6 = 9. "$
5. To determine easily the drilling point on the ceiling, you can fit with the crew C53, the tread L25 onto the support N20 without tightening it definitively. In this manner it will be easy to sign the drilling points in line with the holes in the plate of the final support. Drill with bit $\varnothing . "$ (fig.4) (fig.5). Tighten the final support N20 on the ceiling with the articles C48 checking the horizontal line of the stair.
6. Prepare the tie-rods C22 inserting the flat washers C20 with the knurled surface towards the support flange and the nuts B99. Fit the elements N24 to the supports N21, N22 (fig. 3). Insert, without tightening, the screws B07, B06 and B23. Insert the tubes C21 into the internal part of the elements N24; the tie-rods C22; the flat washers C20 with the knurled surface towards the support flange and the nuts B99. Set the measure of the going (P): for the straight treads the measure (P) is like calculated before (see point 4). For the angle treads the going has a measure (P) of:
 $7\frac{7}{8}$ " (fig.2A) for the version with the tread width (railing included) L=74 .
 $9. "$ (fig.2B) for the version with the tread width (railing included) L=89
Fasten definitively the crews B07, B06 and B23. Proceed with the assembly of all the supports N21. Screw the tube with the threaded tie-rod N25 to the support 2nd rise N22 until the end.
7. Insert the articles C13 and B02 into the elements F23. Fit the elements F23 with the articles C57 on level with the fore edge of the treads L25 upside down (on the side with the holes). Drill with bit $\varnothing\frac{1}{8}$ " to a depth of $1\frac{1}{8}$ " (fig.1) (fig.7).
8. Fit the tread L25 to the support N20 with the screws C53. Check the horizontal line of the tread and tighten definitively the articles C48. Put on the article D34 to cover the bracket with the help of the elements B12 and C62, drilling with bit $\varnothing . "$ (fig.4) (fig.5).
9. Fit an intermediate support N21 into the final support N20. Fasten it below by means of a self-blocking clamp before tightening. Assemble the tread by using the screws C53. (As you proceed with the assembly of supports and treads, it is necessary to prop-up the supports with a mechanical steel prop, so that the ceiling will not have to bear too much weight). It is necessary to put a piece of wood under every 4 to 5 supports and it is strictly forbidden, for safety reasons, to get on the stair before having fixed it to the floor (point 13) and strengthen it (point 14). Adjust the height of the rise that you have calculated in point 2; check the horizontal position of the tread and the alignment with the tread previous tread. Tighten finally the pieces B99 by both side of the support, in order to avoid that the tread is to be modified in its trim (horizontality and verticality) . Proceed in the same way with the assembly of the remaining intermediate supports N21. On the angle treads (see FIG.8) it is necessary to carry out the drillings for connection with the supporting element, according to the chosen winding direction (drill with drilling bit $\varnothing\frac{3}{8}$ " for a depth of $1\frac{1}{8}$ ").
10. (See FIG.9) – Fit the elements F23 onto the internal side of the angle treads L26, L27, L28 by using the elements C57 (drill with drilling bit $\varnothing\frac{1}{8}$ " for a depth of $1\frac{1}{8}$ "). To determine the position, use a baluster C03 as a vertical guide reference.
11. Insert the second-last support N22 (with the two articles N24 which are already inserted in) into the support N21. Assemble the treads with the screws C53. Set up the rise which had been calculated before (look at point 2).

- Unscrew the article N25 until the floor. Insert the support N23 and assemble it to the article N24. Fix the tread. Control the horizontal and vertical line of the tread before and tighten definitively the articles B99.
12. Check for vertical position of the whole staircase and, if necessary, adjust by shifting the support N23.
 13. Disassemble the first tread and mark the holes on the floor. Drill the floor with bit Ø. " in accordance with the holes which are on the support N23. Insert the plugs C47 and tighten definitively (fig.1)
 14. (See FIG.15) – Reinforce the staircase on the following places: a) at an intermediate level of the staircase position the pole G08 to the floor, by using the articles D31, C35 et B20. – b) connect the staircase to the wall by using the element F12 together with the articles B13 (drill with drilling bit Ø. ") and the screws C57 (drill with drilling bit Ø $\frac{1}{8}$ ") strictly in the shown points. Cover with the element B95.

Assembly of the railing

15. (See FIG.6) – Fit the elements B65, C59, C54 into the balusters C03 by using the tube B68 to hammer in.
16. Assemble the elements F23 onto the straight treads using the upright C03 to determine the ideal position (the use of a spirit-level is advised). Mark the holes in accordance of the element F23. Drill with bit Ø $\frac{1}{8}$ " with a depth of $1\frac{1}{8}$ ".
17. Insert the connecting balusters C03 between the treads. Position the balusters in a way, that the holes of the fixing element B65 be turned upwards as in FIG.6. Tighten the elements B02 to the article F23.
18. Take the distance between the three angle treads and cut on measure an upright C03. Connect afterwards with the help of this upright piece the three angle treads (Fig.9).
19. Fit on the floor, in accordance with the first upright (C03), the element F01, drilling with bit Ø. ". Use the elements C58, B12 and B02 (fig.1). Assemble the reinforcing element F07 at the first upright.
Pay attention: the first upright must be cut considering the height of the other uprights.
20. Custom cut the handrail segments A11 (fig.10); assembly them with article B51 (fig.11). In order to obtain a perfect fitting, the handrail must do about an 1/8 rotation from the contact point, to the alignment point of the lower slots (fig.12); if that does not happen, turn enough the thread element of the handrail, screwing it, with elements B44 and B35 (fig.13). Fix the element A09 with article C43 (fig.1).
21. Connect the handrail to the balusters, by means of the article B49. Check the vertical position of the balusters.
22. Position the element F23 in the middle of the two uprights C03. Cut the uprights of the middle C03 in the height considering the rest of the stair railing. Cut the intermediate balusters C03 to a length that has to be measured on the railing.
23. Insert the intermediate balusters C03. Position the balusters in a way, that the holes of the fixing element B65 be turned upwards as in FIG.14. Tighten the articles B02.
24. Connect the balusters to the handrail by means of the screws B49. Check the vertical position of the balusters.
25. (See FIG.14) – In order to reinforce the railing it is necessary to use the following elements :
a) – See drawing FIG.14, below – connect together two balusters by using the elements F08, C49, C50 and a piece of tube C03.
b) – See drawing FIG.14 above – connect a baluster to the wall by means of the article F09 together with the pieces F08. Drill with drilling bit Ø. " and use the articles C49, C50, C58, B12.
26. (See FIG.14) Complete the assembly of the railing by fitting the pieces B82 to the bottom of the balusters.
27. (See FIG.1) – Fit onto the supporting elements the lower closing lids D27, D28, D29.
28. (See FIG.1) – Fit onto the supporting elements the lateral closing lids D30, proceeding as follows :
a) Hook the back side of the lid onto the curved side of the support.
b) Press the lid to the metal sheet, until the two elastic hooks spring into the holes.

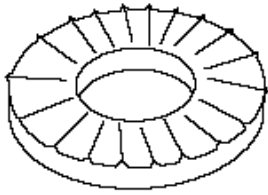

C20

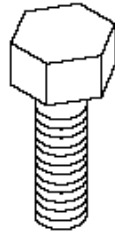

B07

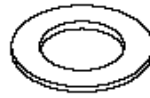

B06

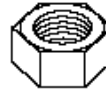

B23

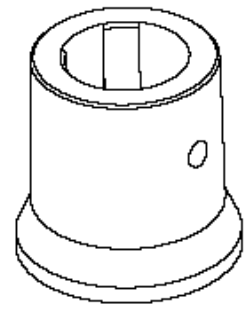

F01



B02

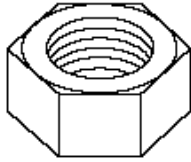

B99

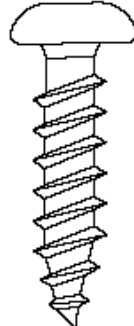

C53

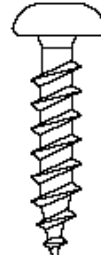

C57

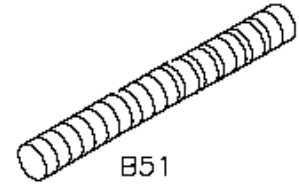

B51

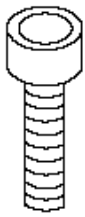

C50



C49

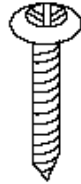

B49



C54

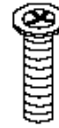

C59

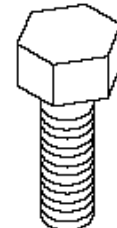

B44

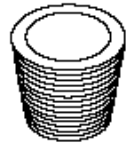

B35

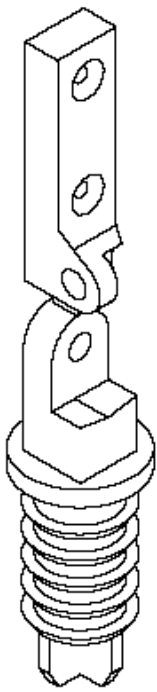

B65



B68



B82



C13

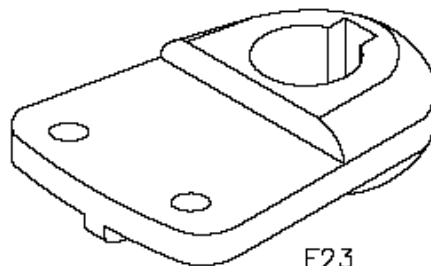

F23

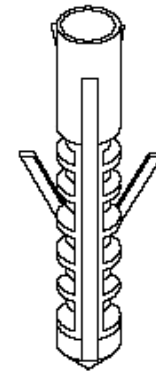

B12

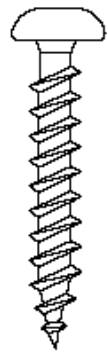

C58

FIG. 1

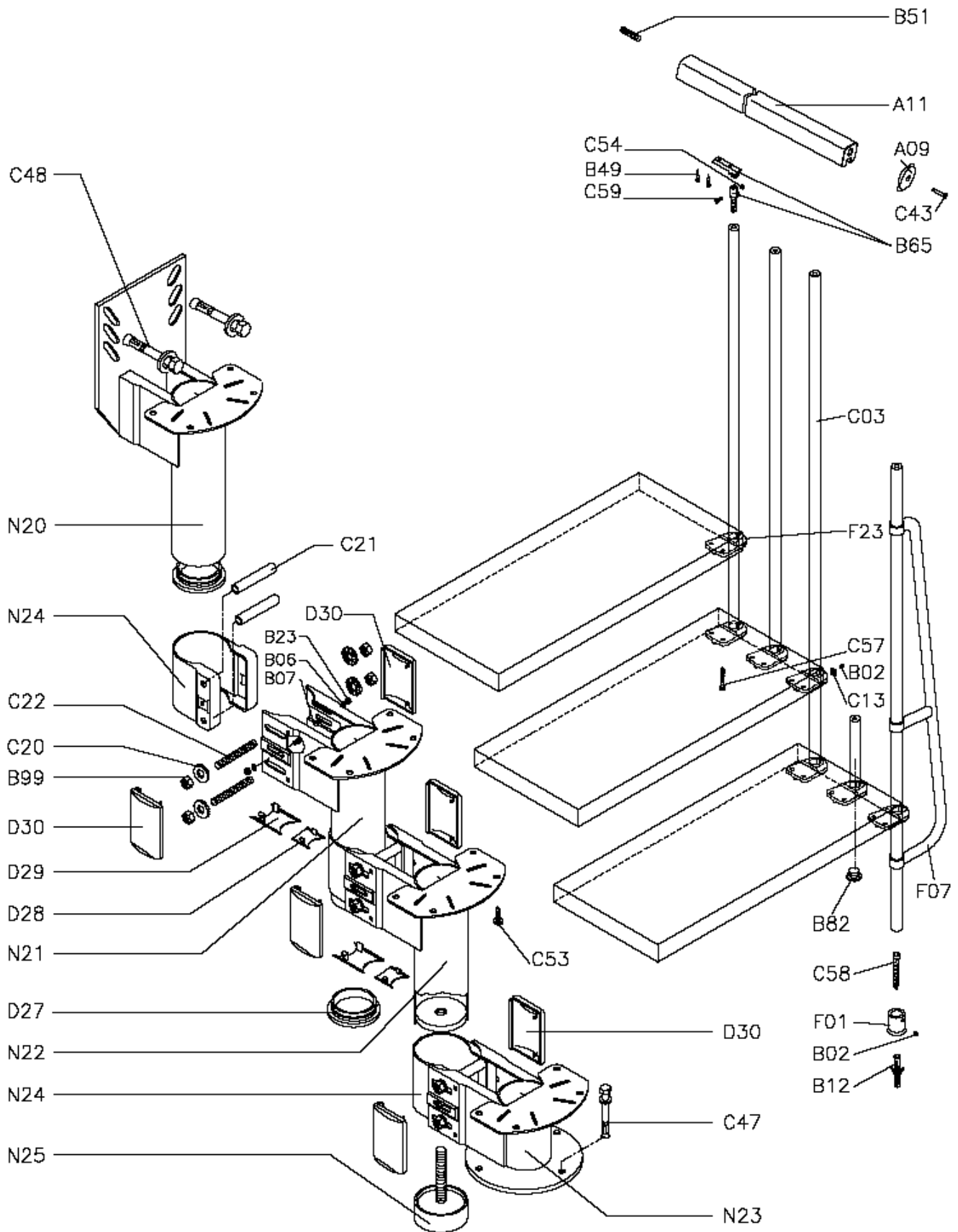

FIG. 2

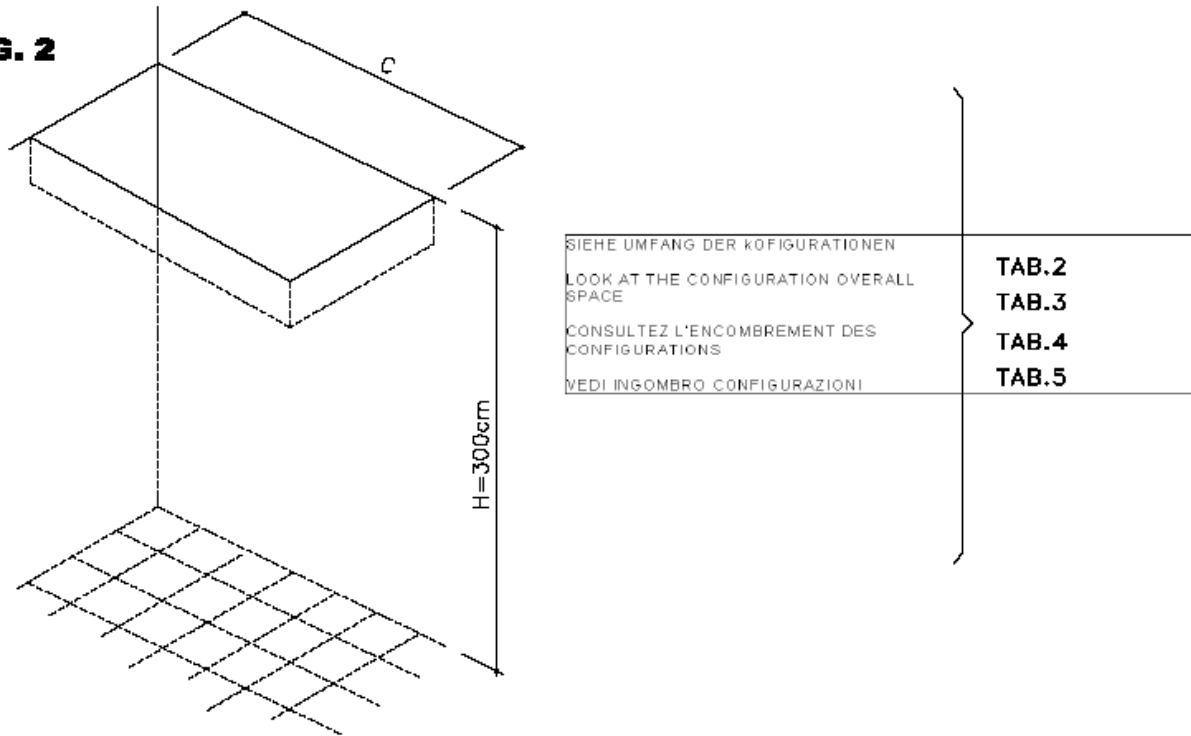

FIG. 2A

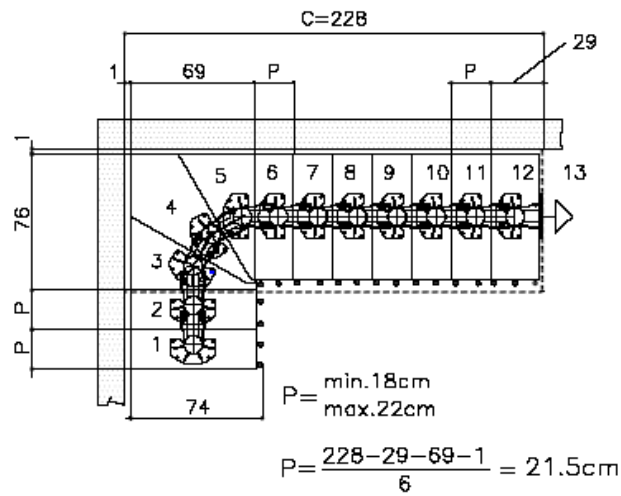

FIG. 2B

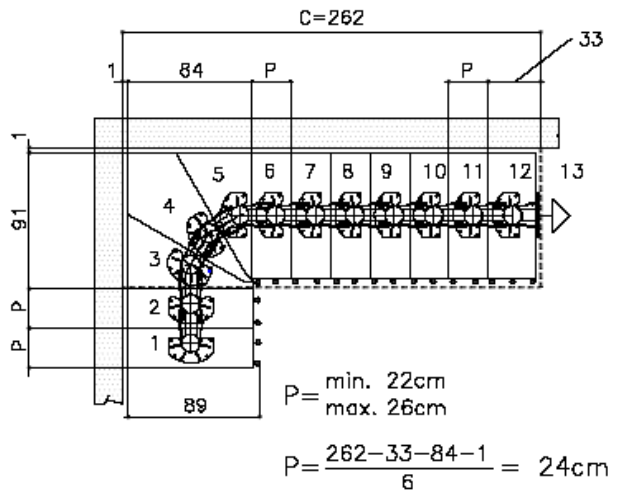

FIG. 3

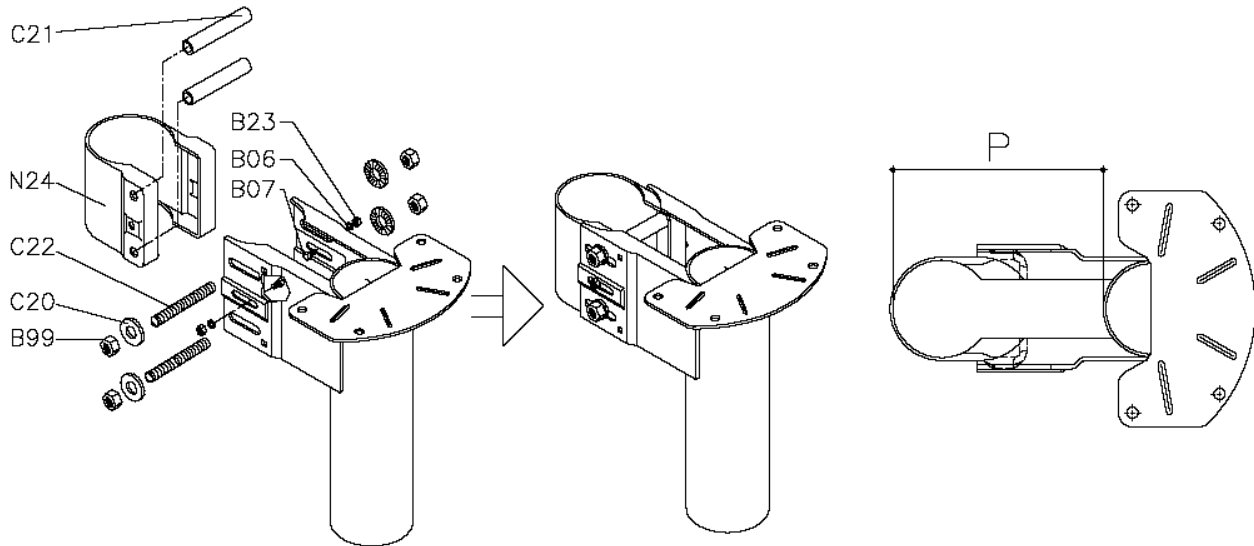

FIG. 4

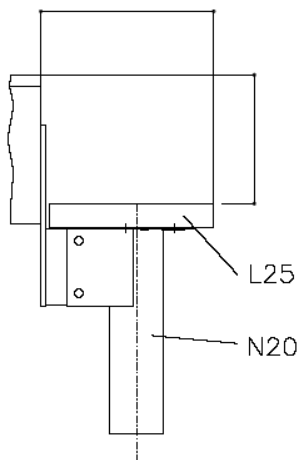

FIG. 5

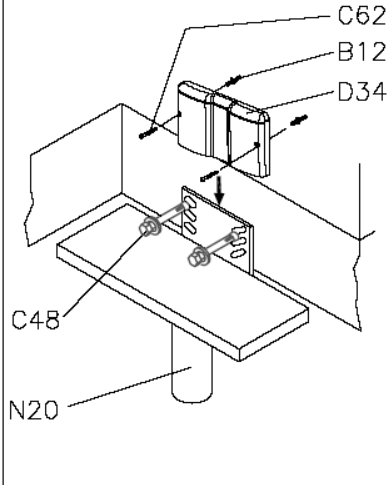

FIG. 6

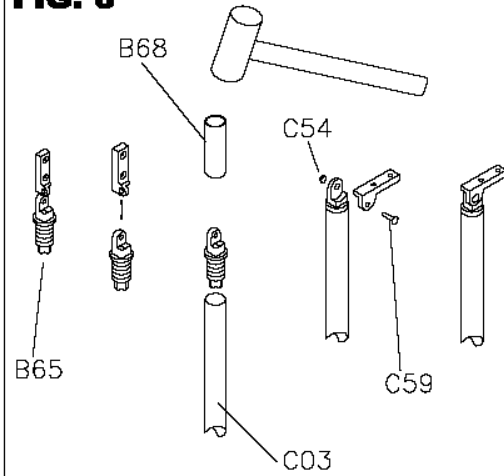

FIG. 7

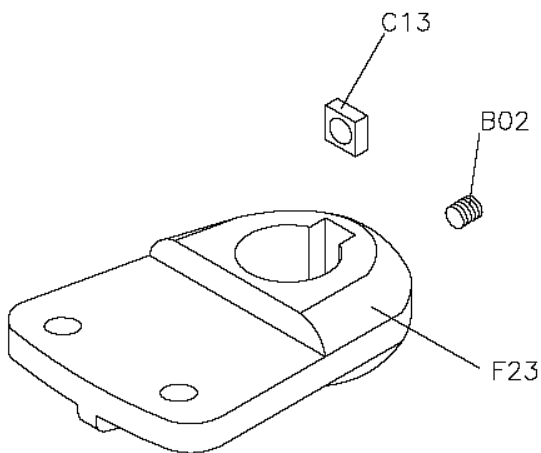

FIG. 8

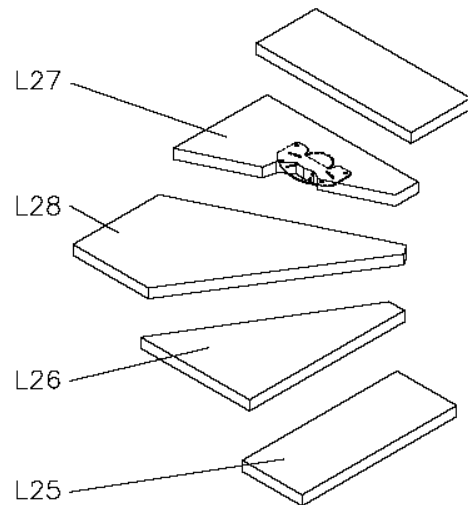

FIG. 9

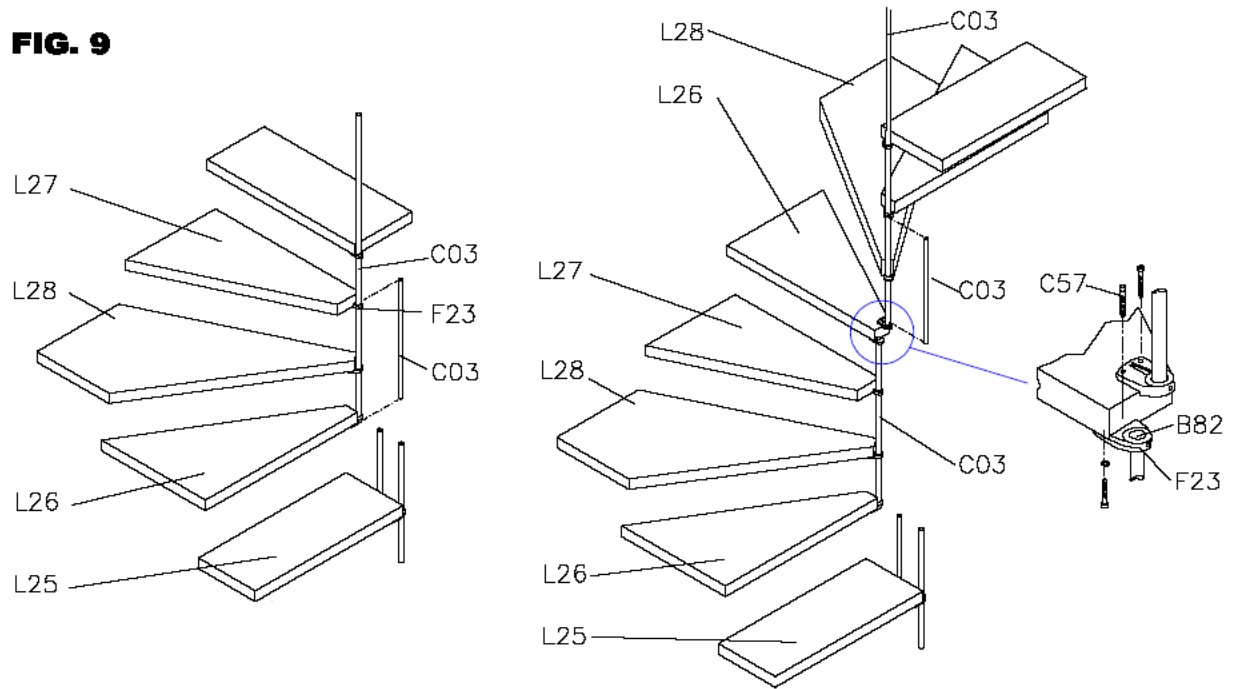

FIG. 10

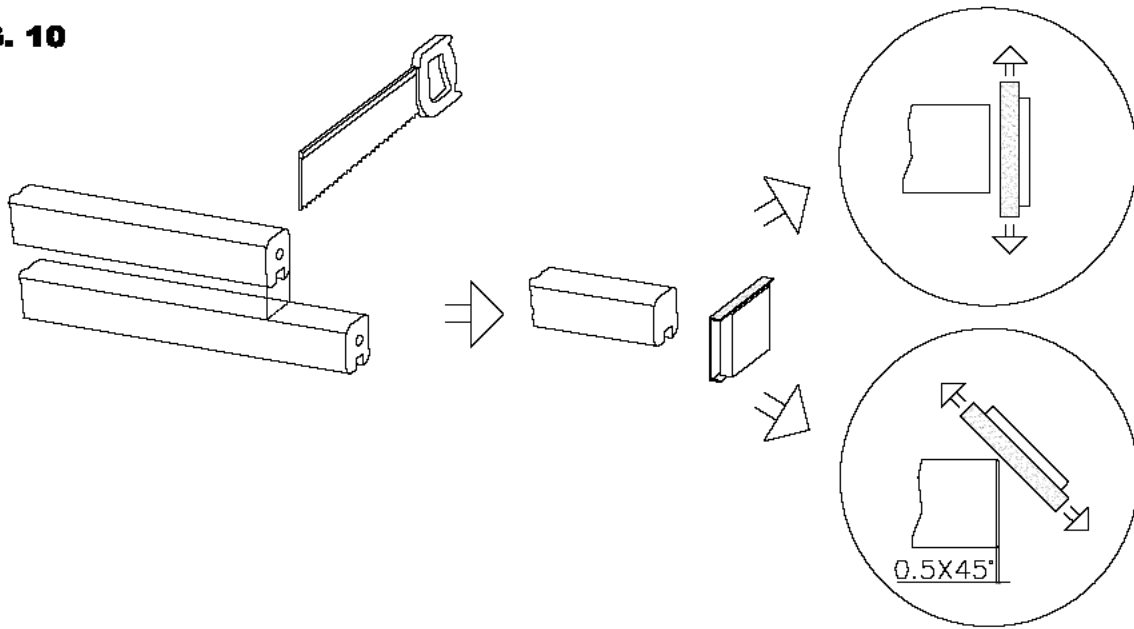

FIG. 11

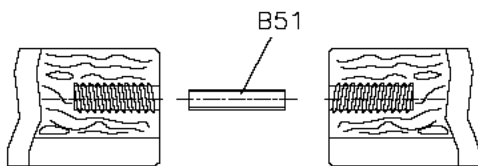

FIG. 12

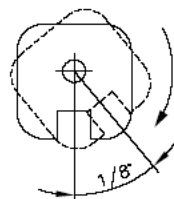

FIG. 13

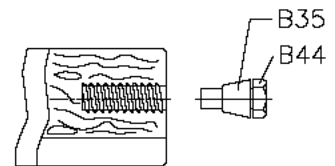
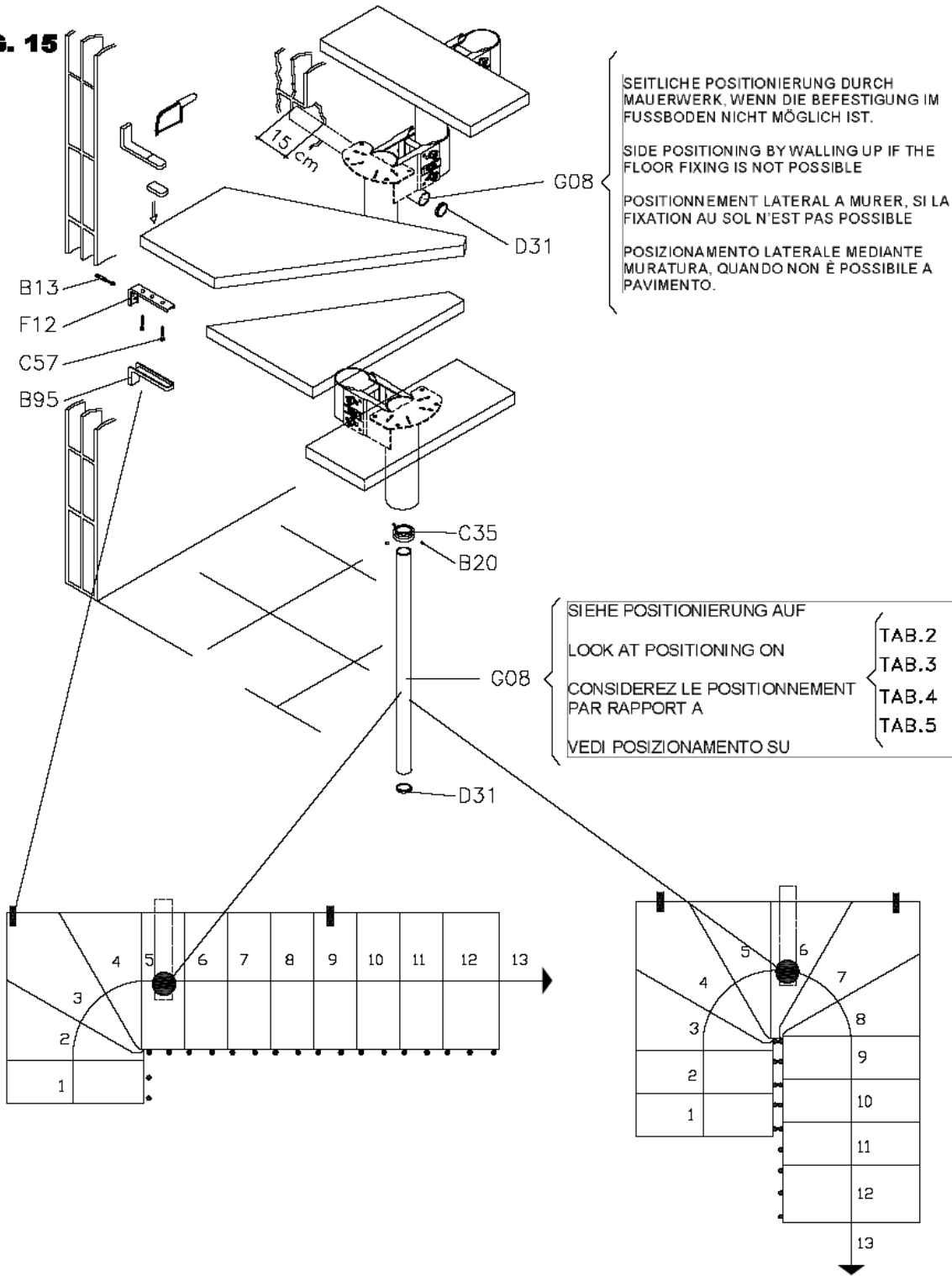

FIG. 15



K35001
 K35002
 K35003
 K35023
 K35024
 K35025

K35016
 K35017
 K35018
 K35026
 K35027
 K35028

KIT EXTERNAL RAILING (composed of 5 balusters, handrail and fixings). From the following drawing it is possible to determine the necessary number of balusters on the external side of the staircase, taking into account the chosen configuration (the balusters are represented by the figures and dots visible on the external side).

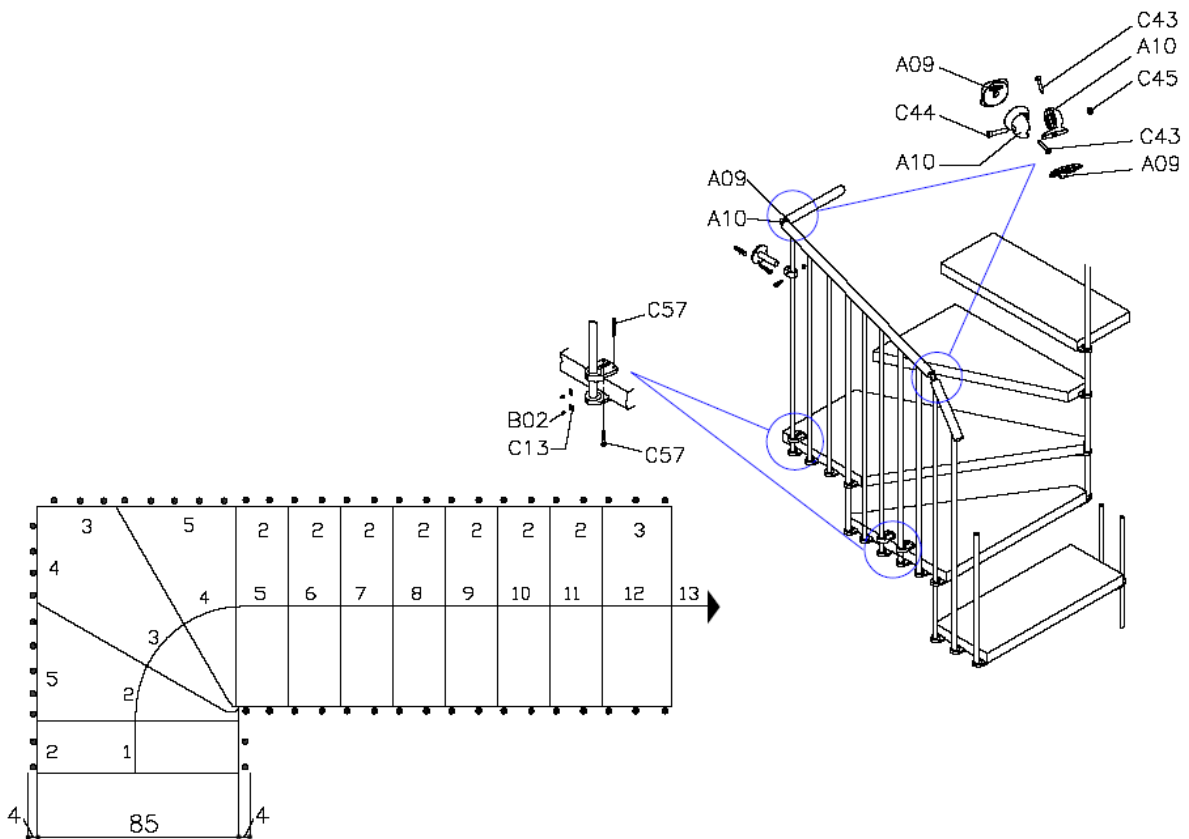
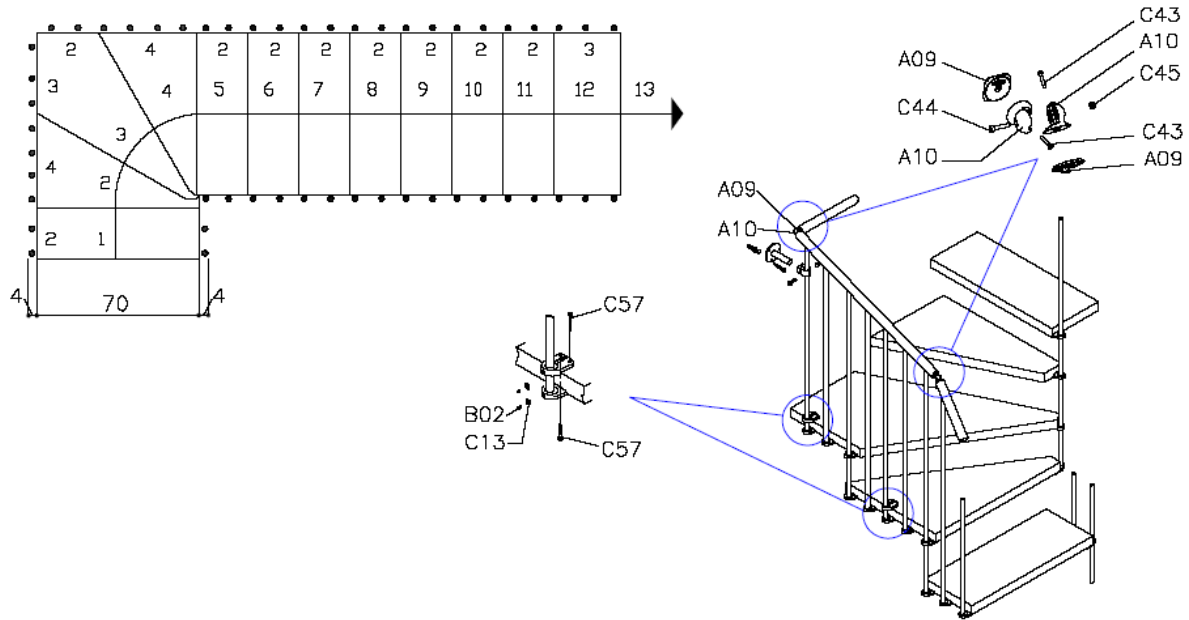

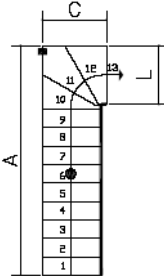
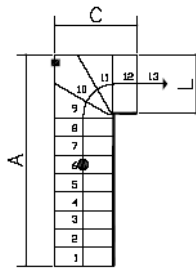
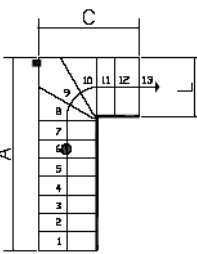
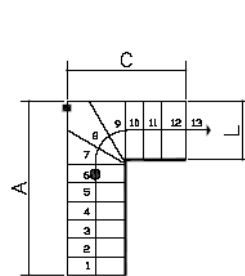
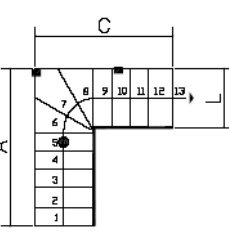
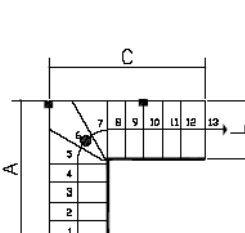
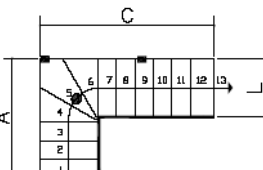
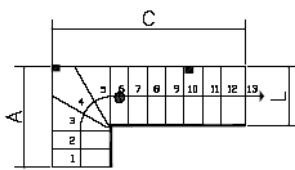
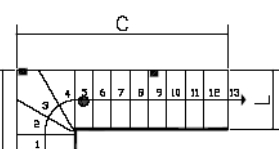
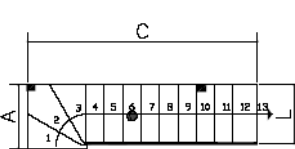
TAB. 2	cm		cm				
	L=74	L=89	L=74	L=89			
	A	238÷274	289÷325		A	220÷252	267÷299
	B				B		
	C	78	94		C	98	117
	A	202÷230	245÷273		A	184÷208	223÷247
	B				B		
	C	116÷120	139÷143		C	134÷142	161÷169
	A	166÷186	201÷221		A	148÷164	179÷195
	B				B		
	C	152÷164	183÷195		C	170÷186	205÷221
	A	130÷142	157÷169		A	112÷120	135÷143
	B				B		
	C	188÷208	227÷247		C	206÷230	249÷273
	A	94÷98	113÷117		A	76	91
	B				B		
	C	224÷252	271÷299		C	242÷274	293÷325

TAB. 3

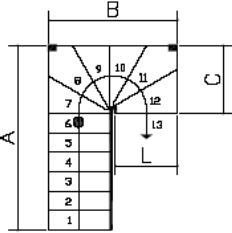
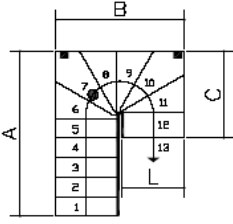
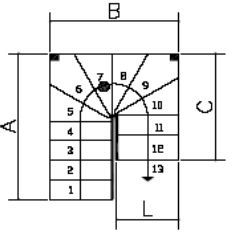
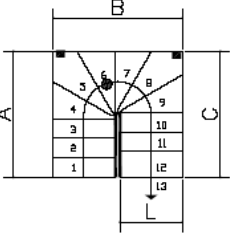
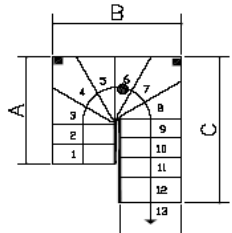
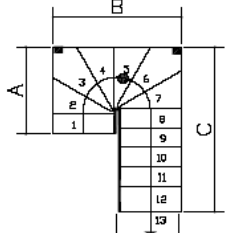
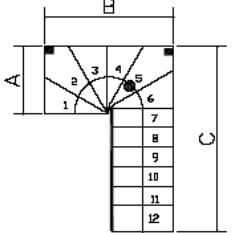
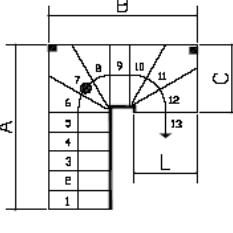
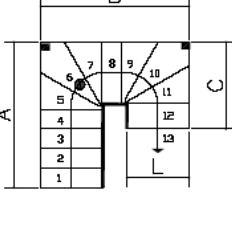
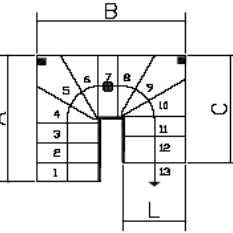
	cm			cm			
	L=74	L=89		L=74	L=89		
	A	184÷208	223÷247		A	166÷186	201÷221
	B	145	175		B	145	175
	C	78	94		C	98	117
	A	148÷164	179÷195		A	130÷142	157÷169
	B	145	175		B	145	175
	C	116÷120	139÷143		C	134÷142	161÷169
	A	112÷120	135÷143		A	94÷98	113÷117
	B	145	175		B	145	175
	C	152÷164	183÷195		C	170÷186	205÷221
	A	76	91		A	166÷186	201÷221
	B	145	175		B	163÷167	197÷201
	C	188÷208	227÷247		C	78	94
	A	148÷164	179÷195		A	130÷142	157÷169
	B	163÷167	197÷201		B	163÷167	197÷201
	C	98	117		C	116÷120	139÷143

TAB. 4

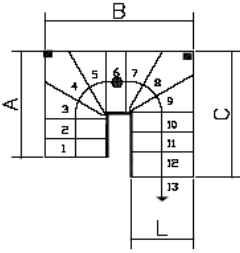
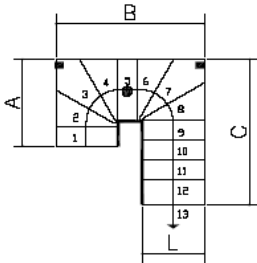
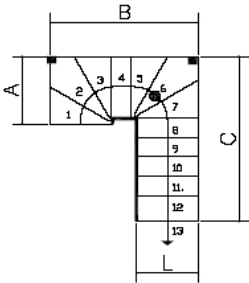
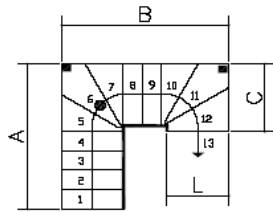
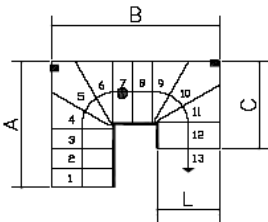
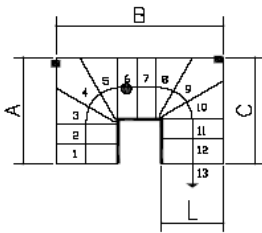
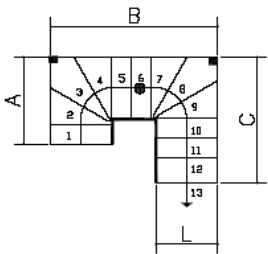
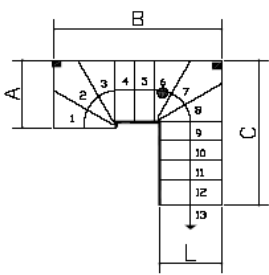
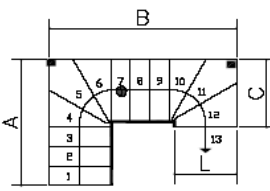
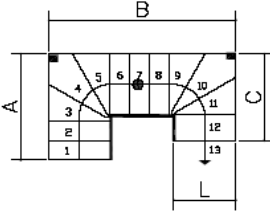
	cm			cm			
	L=74	L=89		L=74	L=89		
	A	112÷120	135÷143		A	94÷98	113÷117
	B	163÷167	197÷201		B	163÷167	197÷201
	C	134÷142	161÷169		C	152÷164	183÷195
	A	76	91		A	148÷164	179÷195
	B	163÷167	197÷201		B	181÷189	219÷227
	C	170÷186	205÷221		C	78	94
	A	130÷142	157÷169		A	112÷120	135÷143
	B	181÷189	219÷227		B	181÷189	219÷227
	C	98	117		C	116÷120	139÷143
	A	94÷98	113÷117		A	76	91
	B	181÷189	219÷227		B	181÷189	219÷227
	C	134÷142	161÷169		C	152÷164	183÷195
	A	130÷142	157÷169		A	112÷120	135÷143
	B	199÷211	241÷253		B	199÷211	241÷253
	C	78	94		C	98	117

TAB. 5

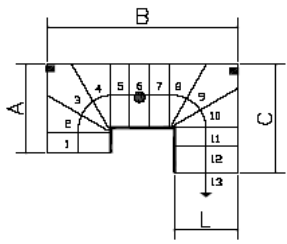
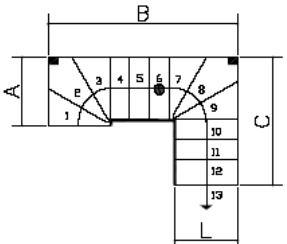
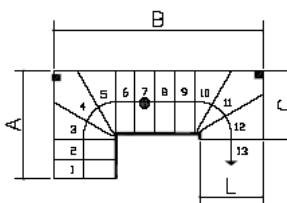
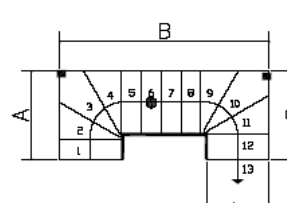
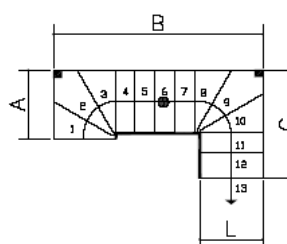
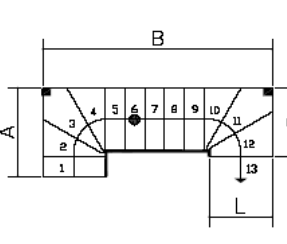
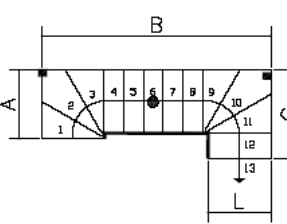
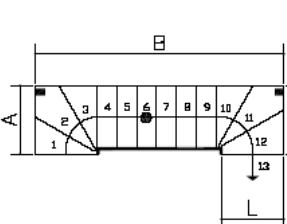
	cm			cm			
	L=74	L=89		L=74	L=89		
	A	94÷98	113÷117		A	76	91
	B	199÷211	241÷253		B	199÷211	241÷253
	C	116÷120	139÷143		C	134÷142	161÷169
	A	112÷120	135÷142		A	94÷98	113÷117
	B	217÷233	263÷279		B	217÷233	263÷279
	C	78	94		C	98	117
	A	76	91		A	94÷98	113÷117
	B	217÷233	263÷279		B	235÷255	285÷305
	C	116÷120	139÷143		C	78	94
	A	76	91		A	76	91
	B	235÷255	285÷305		B	253÷277	307÷331
	C	98	117		C	78	94

